



High Performance Low Voltage Industrial AC Drives

Shanghai Nancal Electric Co., Ltd.

Address: C708, 699 Zhongke Rd., Pudong New District, Shanghai, China

Postcode: 201210

Tel.: 021-5041 0009

Fax.: 021-2042 2388

E-mail: sales.sh@nancal.com

Website: www.nancal.com

Customer service: +86 18217165478



LinkedIn











Facebook

version number: 20201130

Our company has the right to explain the catalogue,
the contents are for reference only.



Medium Voltage AC Drives	Low Voltage Industrial AC Drives	Medium Voltage Soft Starter	APF	SVG	SVGC	SPC	High Voltage SVG	Shore Power
								
2.3kV-18kV	400V/480V/690V	1.14kV-13.8kV	400V/480V/ 690V	400V/480V/ 690V	400V/480V/ 690V	400V	3kV-35kV	High voltage: 6kV-10kV Low voltage: 380V-690V
200kW-15MW (Air cooling) 7MW-65MW (Water cooling)	37kW-8MW	220kW-26MW	30A-750A	30kvar-600kvar	100kvar-600kvar	35kvar-100kvar	1000kvar-100Mvar	High voltage: 300kVA-20MVA Low voltage: 100kVA-8MVA
Draught fan, water pump, compressor energy saving; process speed regulation	High performance single/ multiple variable frequency drive system	Motor soft starting	Harmonic elimination	Reactive compensation	Reactive compensation	Three-phase balancing	High voltage reactive compensation	Marine power supply

Shanghai Nancal Electrical Co., Ltd.

Shanghai Nancal Electrical Co., Ltd. is the holding subsidiary of Nancal (stock code: 603859). The company is specialize in R&D, production and sale of power electronic products, such as APF (Active Power Filter), SVG (Static Var Generator), Medium Voltage AC Drives, Low Voltage Industrial AC Drives, Medium Voltage Soft Starter, High Voltage SVG, Shore Power and so on.

Glories

- High technology enterprise, software enterprise
- Type test reports, CE certification, CCS certification
- 15 patents for invention
- 54 patents for utility models
- 61 software copyrights
- Science and technology special award of Chinese Machinery Industry



NC EVFD Introduction

Introduction

NC EVFD series Low Voltage Industrial AC Drives are new generation high performance Variable Frequency Drive which has V/F control, speed sensorless vector control and close loop vector control. It can provide the solution for motor drive systems and satisfy the requirements of general industry and special application, the applications including rolling mill, crane, belt conveyor, internal mixer, pump, draught fan and etc. Serving industry including metallurgy, oil, harbor, mine, testing bed, cement, marine, ocean platform, paper, pulp and etc.

Configuration

- Specifications: single drive/multi-drive, two-quadrant/ four-quadrant, power unit/cabinet-type.
- Voltage class: 400V/480V/690V
- Power range: $\leq 8\text{MW}$
- Output power of Single Inverter Unit (INU): 45kW ~ 560kW
- Rectifier: Diode rectifier unit (DSU), IGBT PWM rectifier unit (ISU1), IGBT 6-pulse rectifier unit (ISU2).
- Motor: AC asynchronous motor, permanent magnet synchronous motor (PMSM), excitation synchronous motor.
- Control mode: V/F control, speed sensorless vector control and close loop vector control.
- Various Interface: RS232, RS485, Profibus, Profinet, CAN, Ethernet and etc.

Product Features

- High performance vector control, motor parameter auto tuning and online identification.
- DSP+FPGA+ARM, high speed digital control.
- High power density, high reliability.
- Customer designed for special application.
- Applied film capacitor, no series connection of capacitors, no voltage-sharing device.
- N8i power unit with output du/dt filter as standard (optional for N6i, N7i power units).
- Redundancy design, maximum 16 power units in parallel without paralleling reactor
- The distributed cooling design, improves thermal performance, suitable for heavy load and impact load.
- Isolated air duct design, immunity to dust
- High reliability external rotor draught fan, low maintenance requirement.
- Easy installation and maintenance
- Real time monitoring, wire and wireless data exchange, remote analysis.

Product Composition

HMI

- Intelligent touch panel, sophisticated interface
- High resolution LCD display
- English and other languages

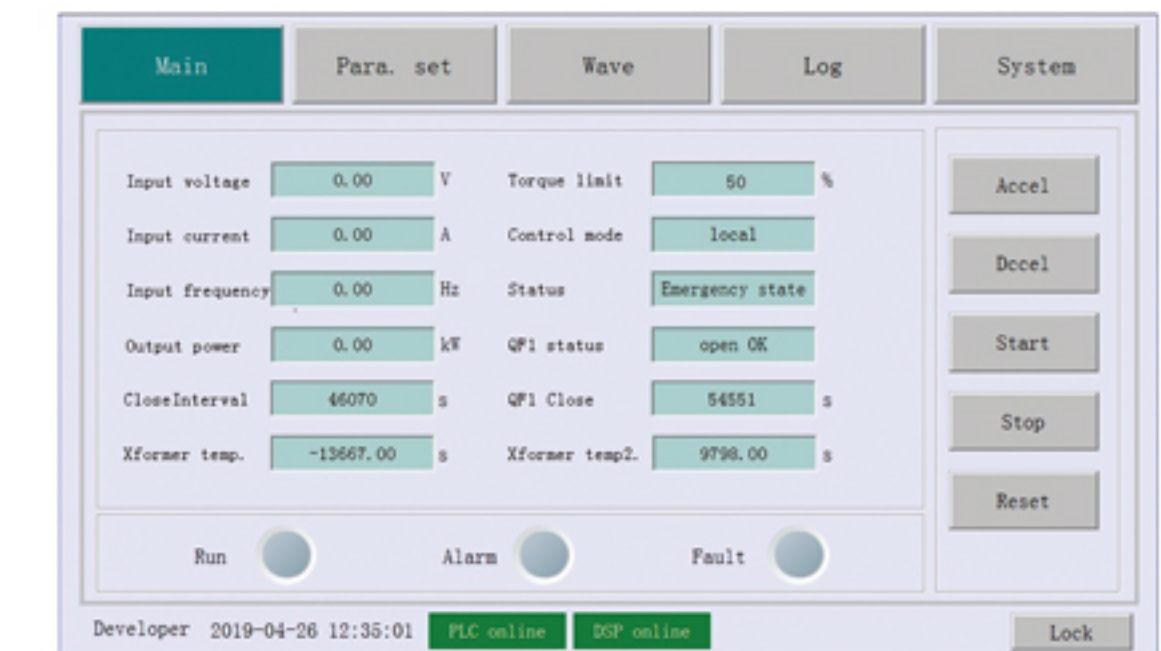

Integrated Control Board

- 32 bit DSP+FPGA+ARM, high speed digital control.
- High reliability full digital control board, compatible to various industrial network.
- Fiber optic interface between core control and power unit, better EMC.
- Abundant interface, such as digital I/O, analog I/O, field bus, encode, etc.

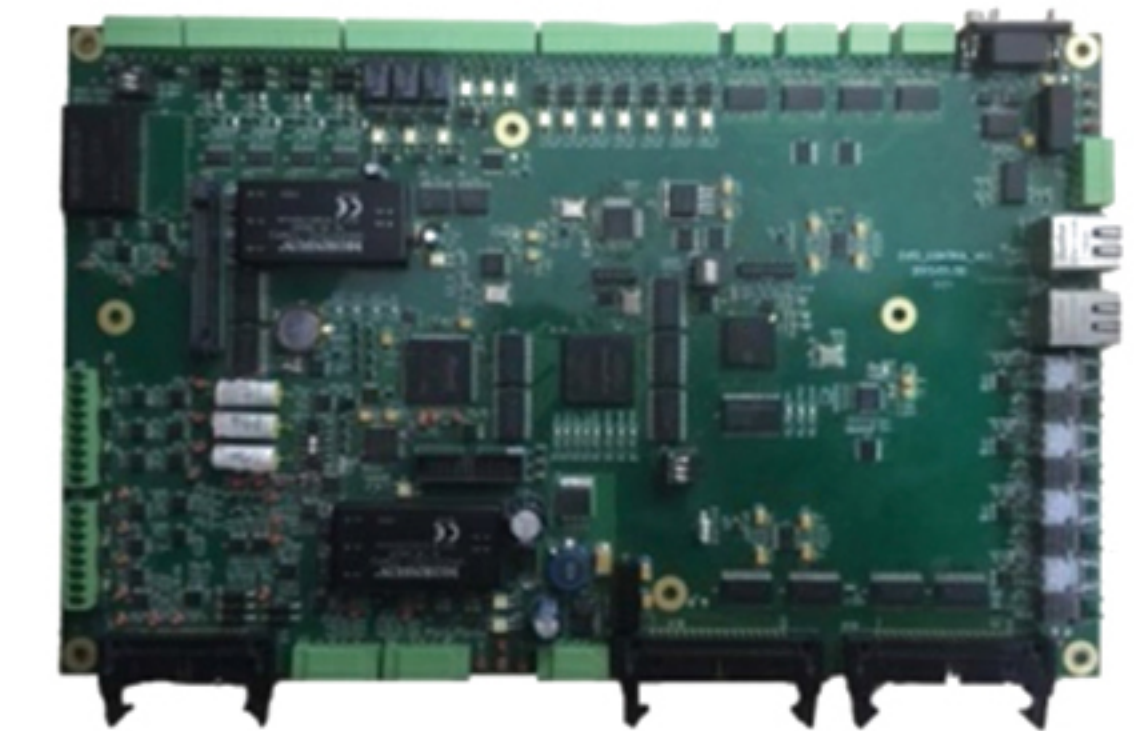

Power Unit

- High power density, 690V/1100kW as example, the width of inverter cabinet is 600mm.
- Adopt the latest generation IGBT, high junction temperature (175°C), low loss and high reliability.
- Castors at the bottom of power units for easy plug in/out, easy maintenance.

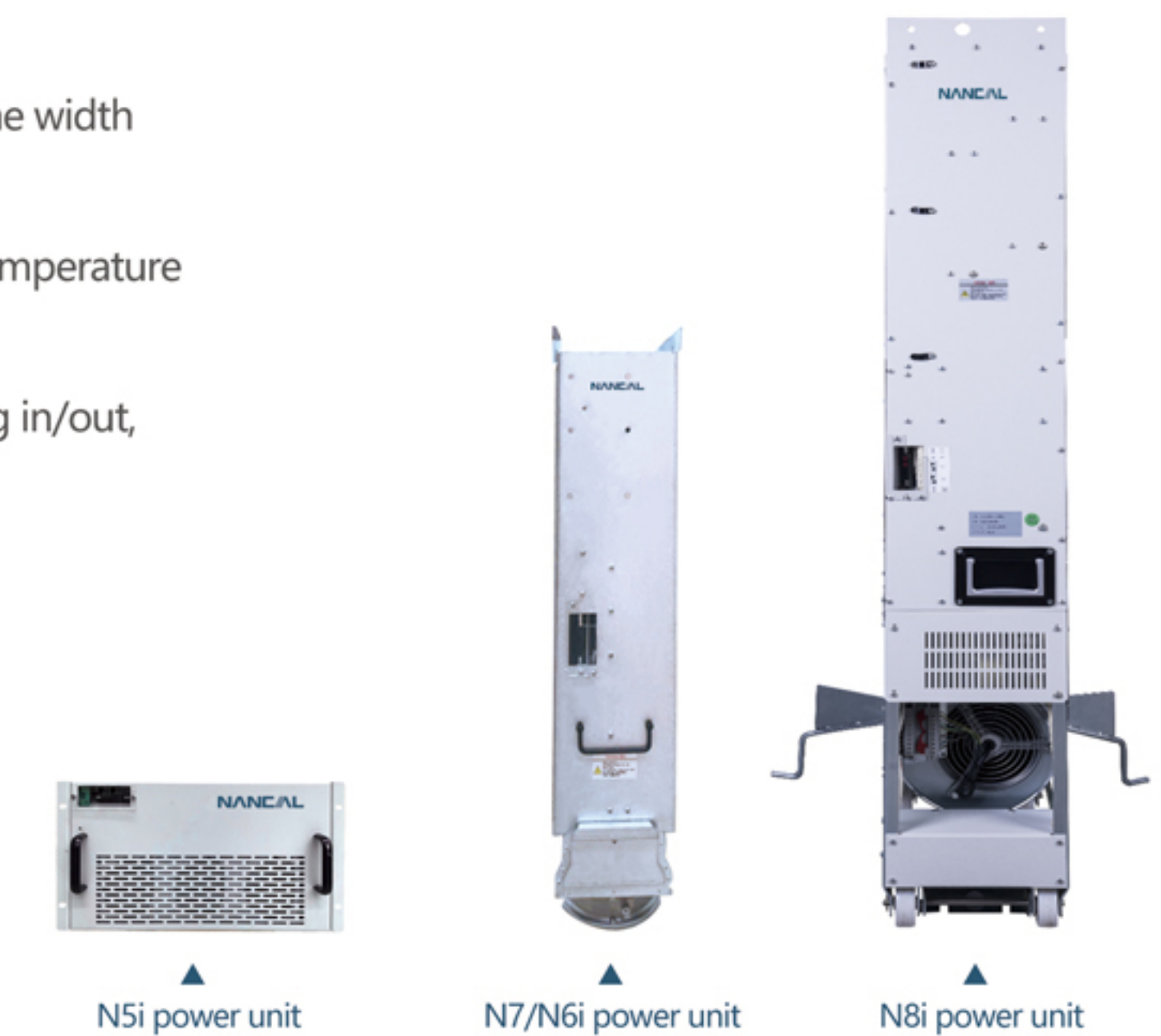

Fuse Disconnection Switch (optional)

- Combine isolation and protection, supporting both online maintenance, safe and reliable.
- High breaking capacity, safety protection fuse with reliability improved.

Multi-drives Solution

Consist of power units on the common DC bus, DC voltage offered by the centralized rectifier unit choice from simple diode rectifier to advanced IGBT rectifier.

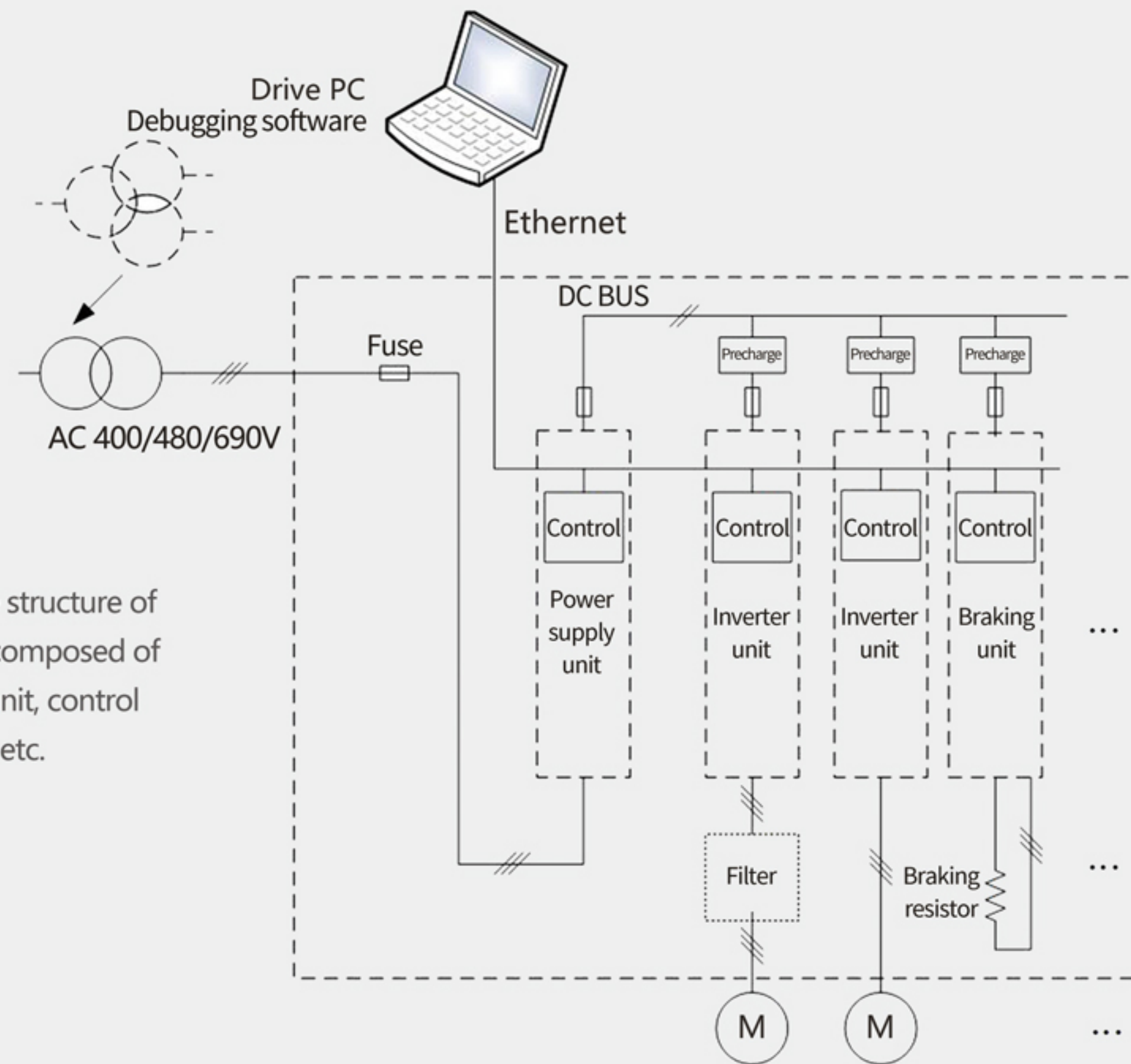

The diagram show the structure of multi-drives, which is composed of rectifier unit, inverter unit, control unit, braking unit, and etc.

Multi-drives structure has following strengths:

- Reducing cost of connection, installation and maintenance.
- Save space
- Less quantity of parts, high reliability
- Low line current and simple braking device
- Energy flow on DC bus, balance between motors, with no or less need for brake chopper or energy feedback unit.
- Centralized rectifier unit improve safety

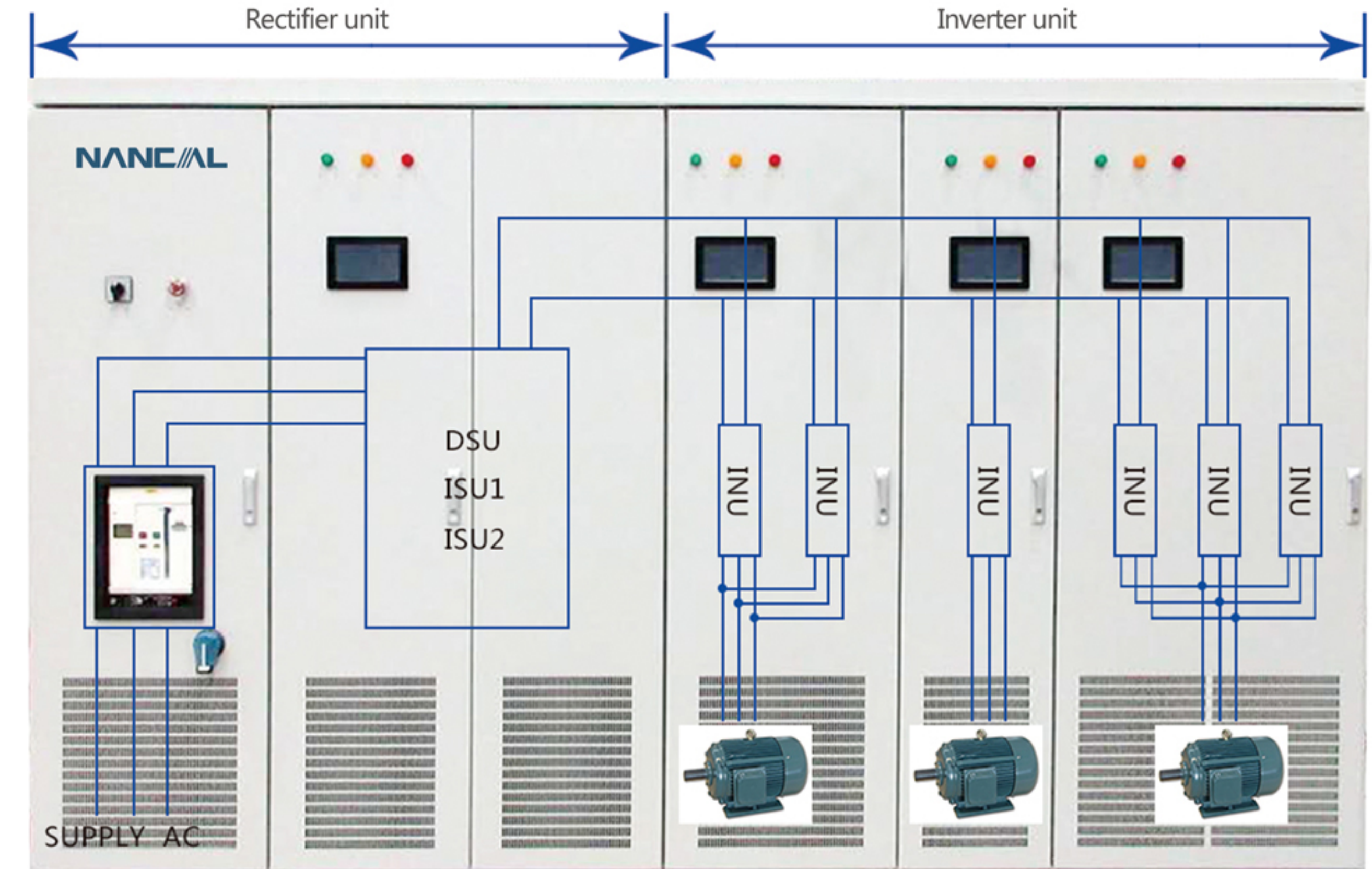

Easy Integration

- Castors at the bottom of power cells for easy installation and maintenance
- Rectifier unit and inverter unit can be paralleled directly for higher current
- Modular design, compact design, easy operating and save space

Performance Advantages

IGBT Rectifier Power Supply

Technical Features

- IGBT rectifier: four-quadrant regeneration, including IGBT PWM rectifier unit (ISU1), IGBT 6-pulse rectifier unit (ISU2).
- Consist of rectifier unit and LCL/L filter
- ISU1 used for low harmonic and regeneration application; ISU2 for regeneration with low cost.

Competitive Advantage

- Accurate phase-locked loop technology and current control, robust to disturbance on grid.
- ISU1 use vector control and LCL filter to minimize harmonic, current THD \leq 5%
- Reactive compensation capacity, unity power factor
- Controllable DC bus voltage (ISU1), less effect by power supply instability.
- IGBT rectifier in parallel directly, power range up to 8000kW, voltage range from 400V ~ 690V.

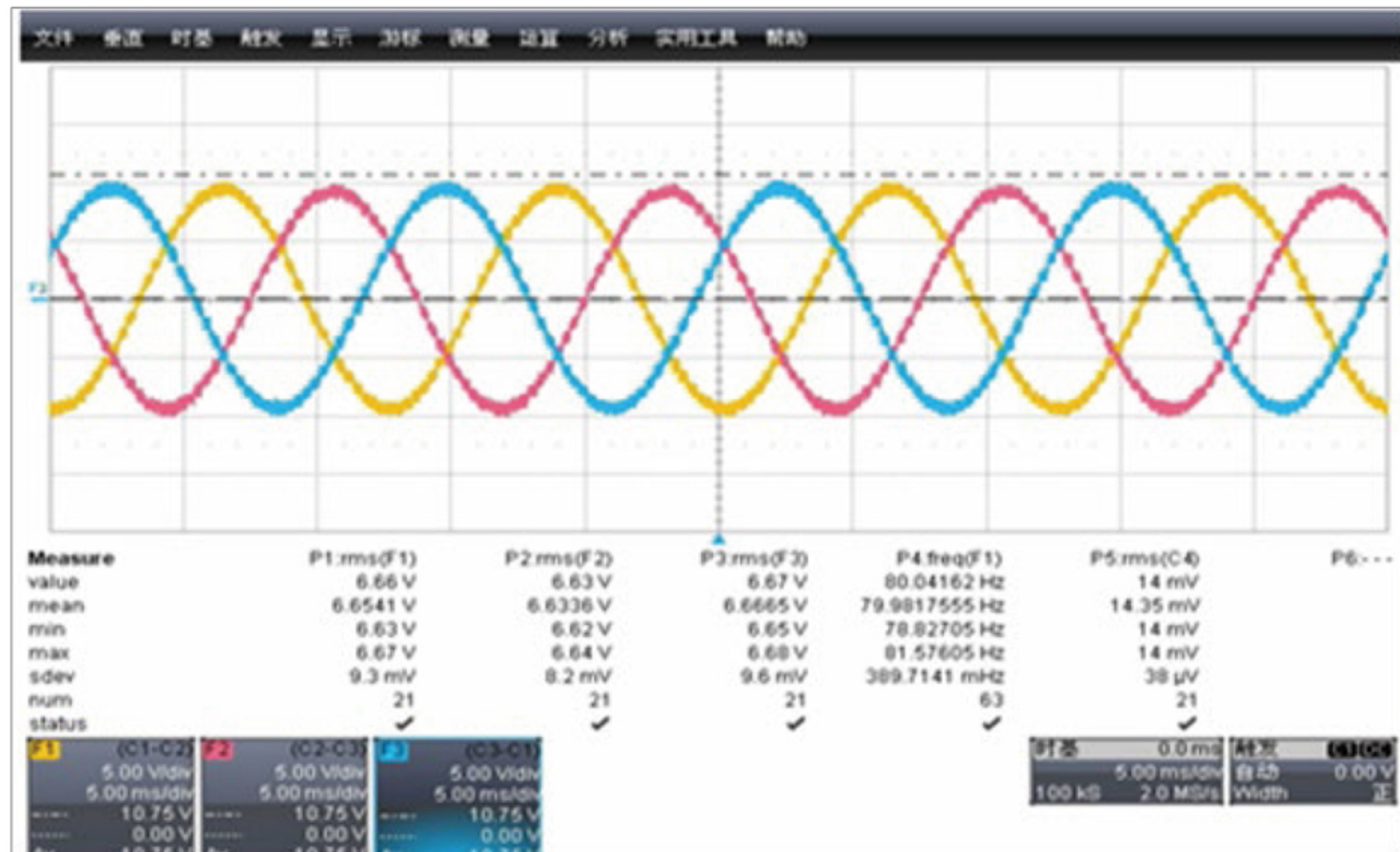

Input Current Waveform: ISU1 (IGBT PWM rectifier unit)

Seamless Transfer when Speed Sensor Failure in Vector Control Mode

Technical Features

Control system estimate motor speed in real time in close loop vector control mode, can transfer to speed sensorless vector control mode seamlessly in case speed sensor fail.

Competitive Advantages

- Minimize loss of motor shut down by speed sensor fault
- Quick and stable transfer, no impact on motor current
- Encoder hardware failure monitoring

Vector Control for PMSM

Technical Features

- Advanced motor flux model, higher torque response and wider flux weakening speed range.
- Multiple control strategies: maximum torque/current (MTPA), unity power factor, maximum efficiency and etc.
- Control modes: close loop vector control, speed sensorless vector control.

Competitive Advantages

- Specialized automatic check for rotor's initial position, high accuracy.

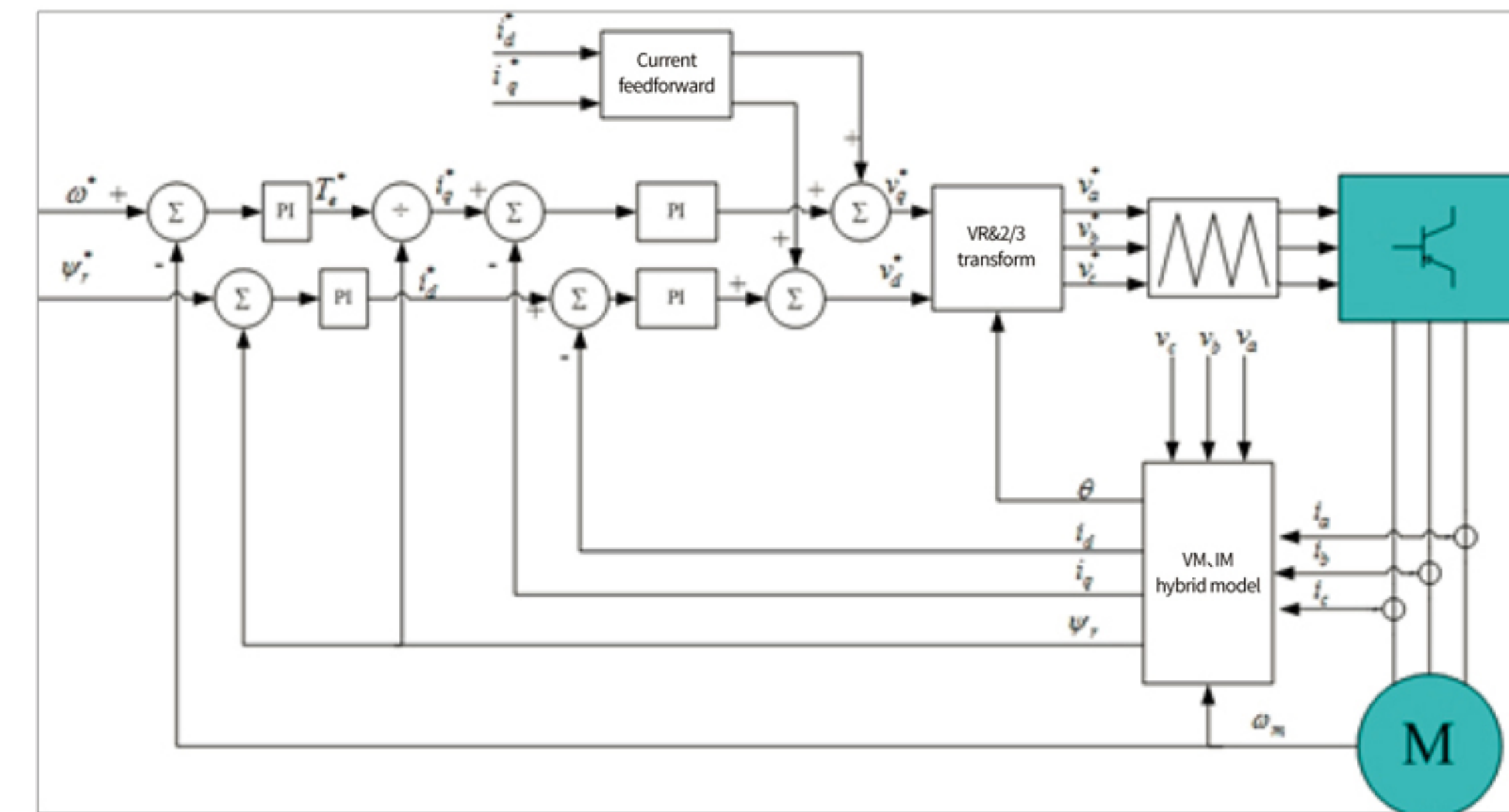

Multi-motor Synchronous Control and Load Distribution

Technical Features

Used for multi-motor driving one load, with synchronous drive and ratio synchronous drive. Satisfy the synchronous drive demand of gear, chain, belt and so on. The applications are rolling mill, winch, spinning machine, papermaking machine, crane, belt conveyor, ship lifting, etc.

Competitive Advantages

- Prevent torsional vibration and slip, high accuracy speed synchronous control and load distribution.

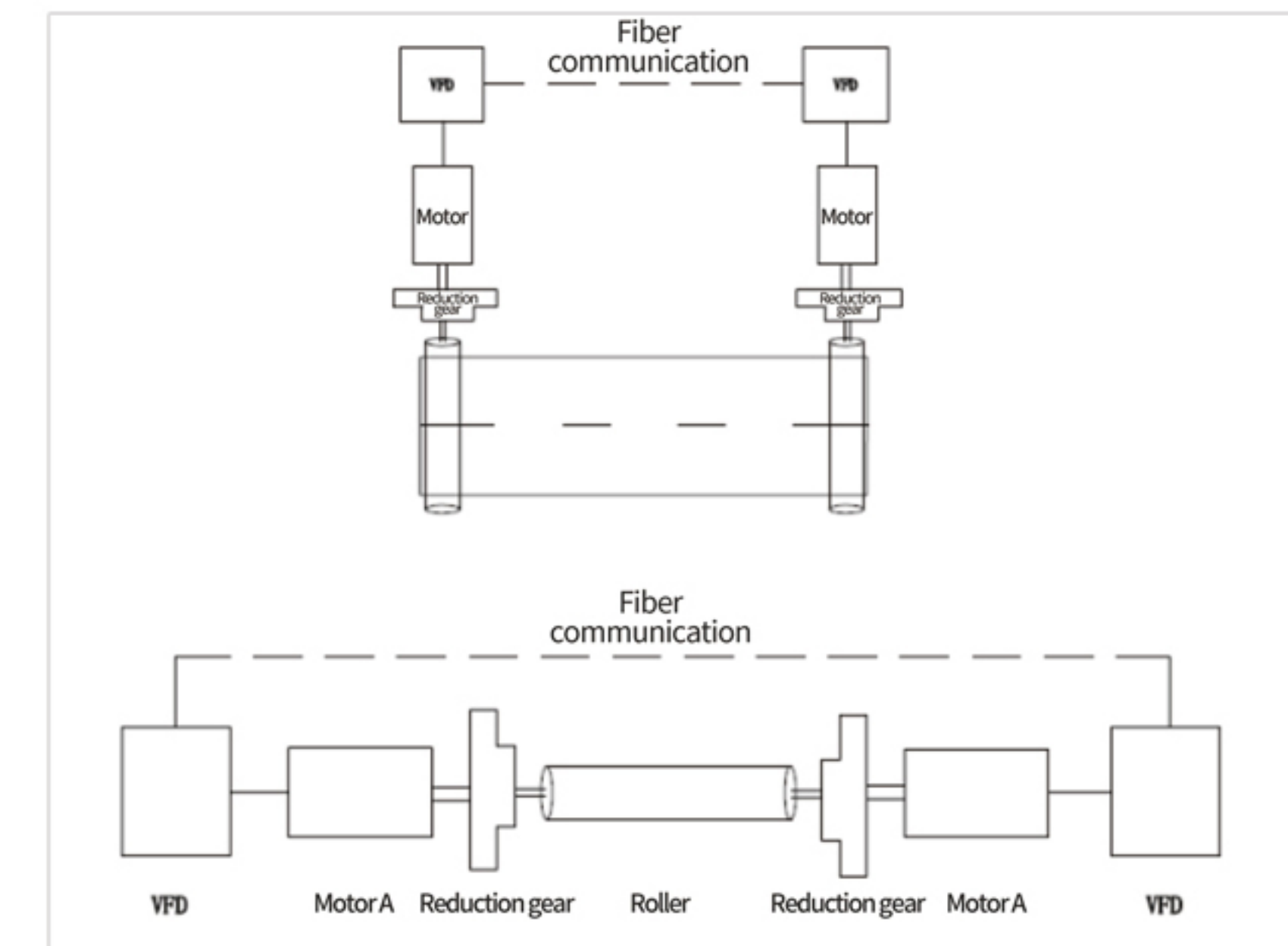

Braking Technology

Technical Features

- **Dual-frequency braking:** add controllable high frequency component on output voltage vector. Parts of rotation energy dissipate via motor winding, and produce high reverse torque, to increase the braking.
- **Magnetic increased braking:** increase the braking torque by increase motor flux.
- **DC braking:** add controllable DC voltage at low speed, eliminate "creeping phenomenon" of drive system.

Competitive Advantages

- Even in diode rectifier configuration, satisfy the strict demand of motor deceleration.

Spinning-load Pick Up

Technical Features

VFD can automatic search motor speed and recover to normal condition according to set time of acceleration and deceleration (i.e. speed tracking technology). When main power supply transfer, system can operate continuously.

Competitive Advantages

- Minimize effect by momentary power supply outages
- Minimize impact on power supply and load

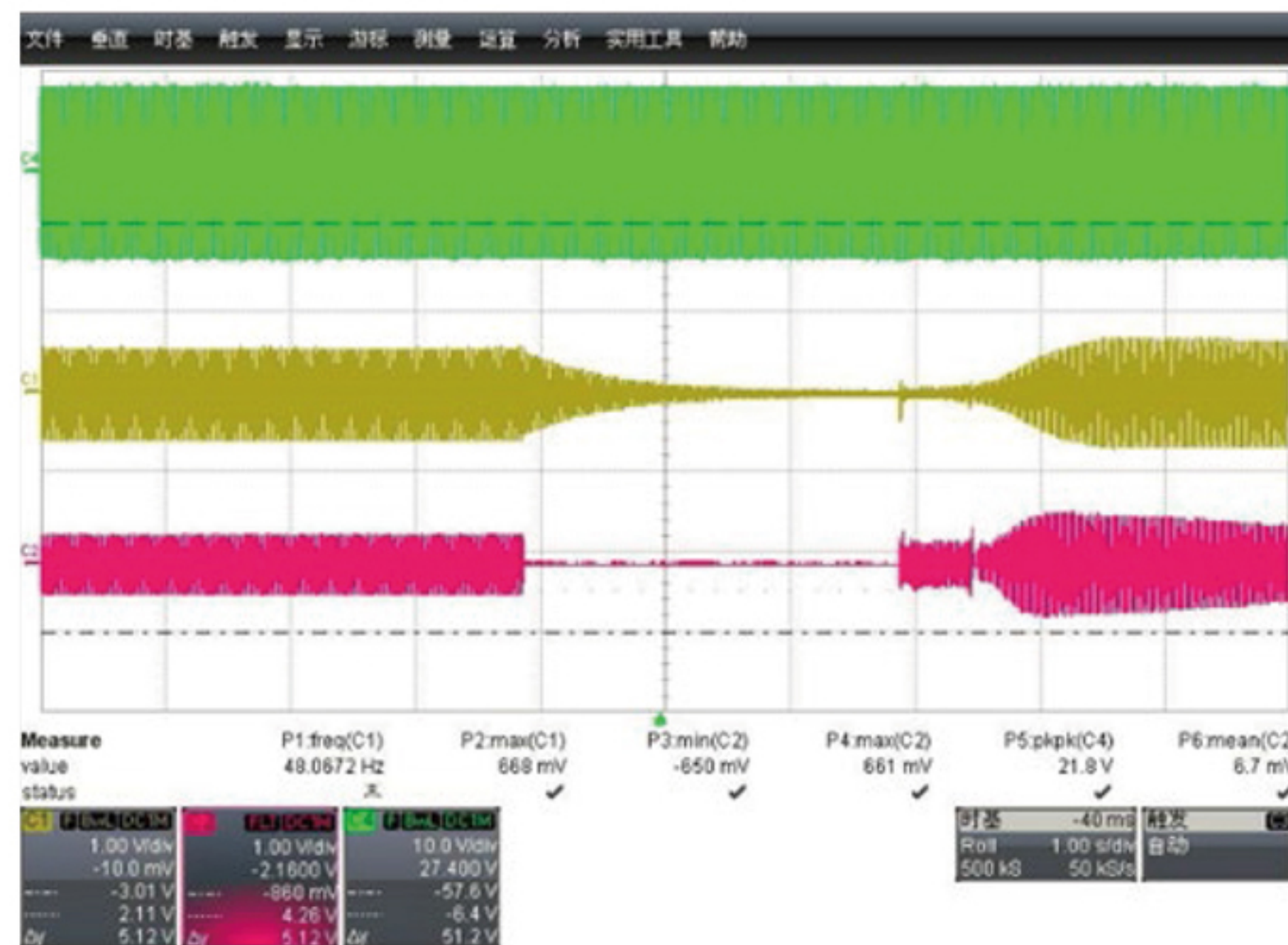

■ yellow-motor voltage ■ red-motor current

Motor Parameter Auto Tuning and Online Identification

Technical Features

Auto tuning for main parameters of motor before running, online identification key parameters changing with working conditions during operation.

Competitive Advantages

Accurate calculate motor parameters used in vector control and regulator parameters automatic optimization, suitable for retrofit project with old motor.

Current Sharing in Parallel Operation

Technical Features

When power cell in parallel operation, current sharing technology via advanced algorithm adjust current in real time without sharing reactor.

Competitive advantages

- Multiple power units in parallel operation
- Derating operation when one power unit fail

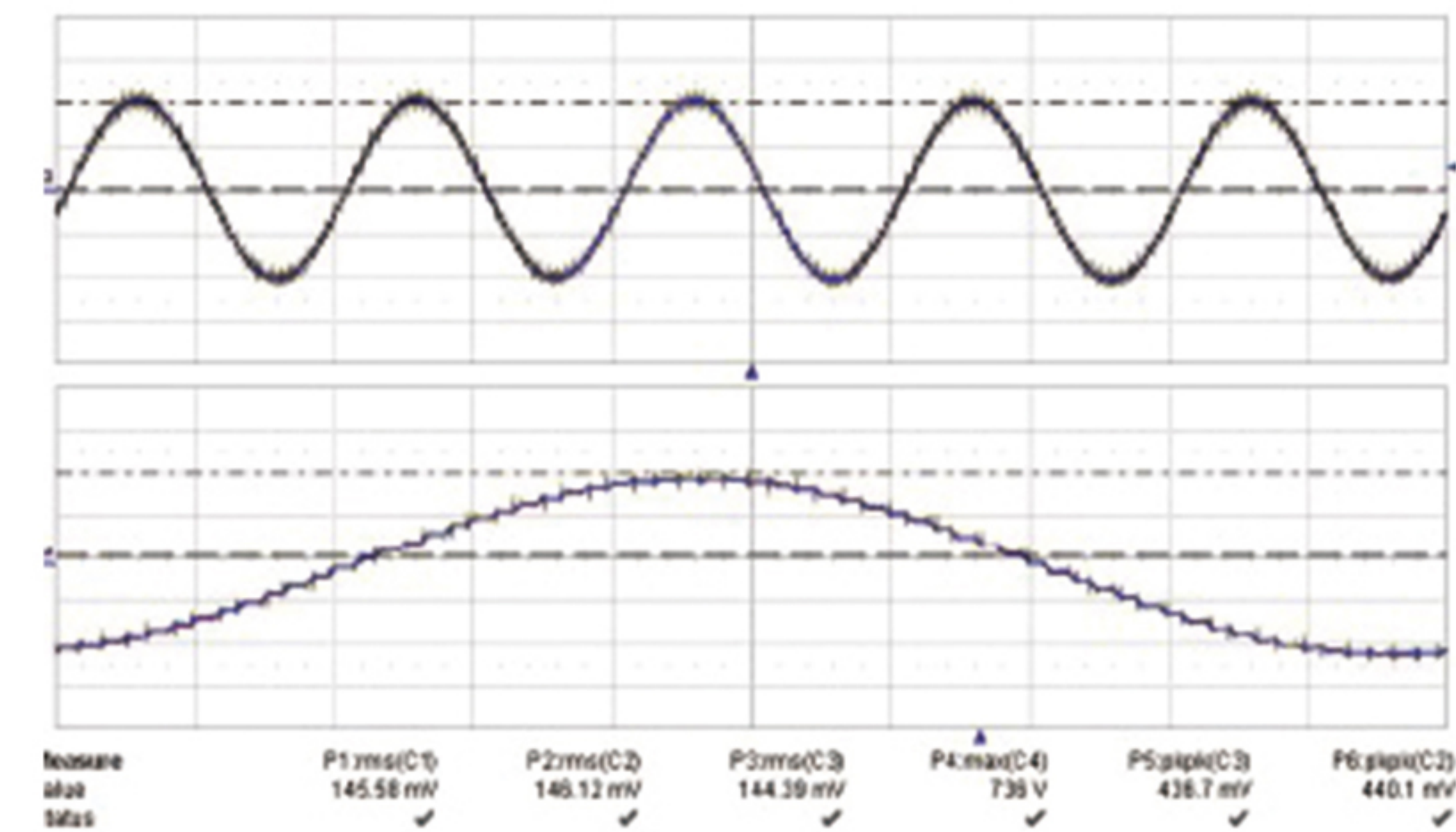

Output current waveform



VFD Auto Diagnosis

Technical Features

Auto diagnosis to IGBT module before VFD running, identify the failed parts, ensure safety.

Competitive Advantages

- Protect VFD
- Quick fault locating

Factory Acceptance Test

System testing

- Self-developed test station for VFD, all VFD will have hundreds of checking items and burn-in test with full load.
- The full load operation can support 400V, 480V, 690V, and four-quadrant regeneration.



Other Technical Features

Protection of Motor (option)

- Temperature of motor winding
- Temperature of motor bearings
- Motor vibration

Thermal Design

- Advanced draught fan, high reliability
- High reliability external rotor draught fan, without dismantle power unit for maintenance
- Large cooling capacity to ensure thermal performance

Self-adaption of Input Voltage

- Closed-loop regulation in real time, ensure stable output voltage when input voltage fluctuation
- Less impact on motor by power supply fluctuation
- Full load operation when fluctuation range of input voltage is -10% (-15%/1 min) ~ +10%

Various Interface

- Communication: Ethernet, Modbus, CAN, Profibus, Profinet, and etc.
- Speed sensor: incremental encoder, absolute value encoder, resolver

Tools for Start and Maintenance

User Friendly Operation Panel

- Color touch screen HMI, abundant interface, support both single drive and multi-drive
- Assistant type operation, easy navigation
- High resolution display
- Display operation condition and fault in real time, describe fault reason and proposed solution.
- Minimize time of debugging and maintenance
- Parameters back up and copy, suitable for multi-drive system

Technical Specifications

Single-drive Model

E.g.
NC EVFD-03-04-0500 represents NC EVFD series Low Voltage Industrial AC Drives single drive, air cooling, diode rectifier, rated output voltage is 400V, rated output power is 500kW when drive asynchronous motor.

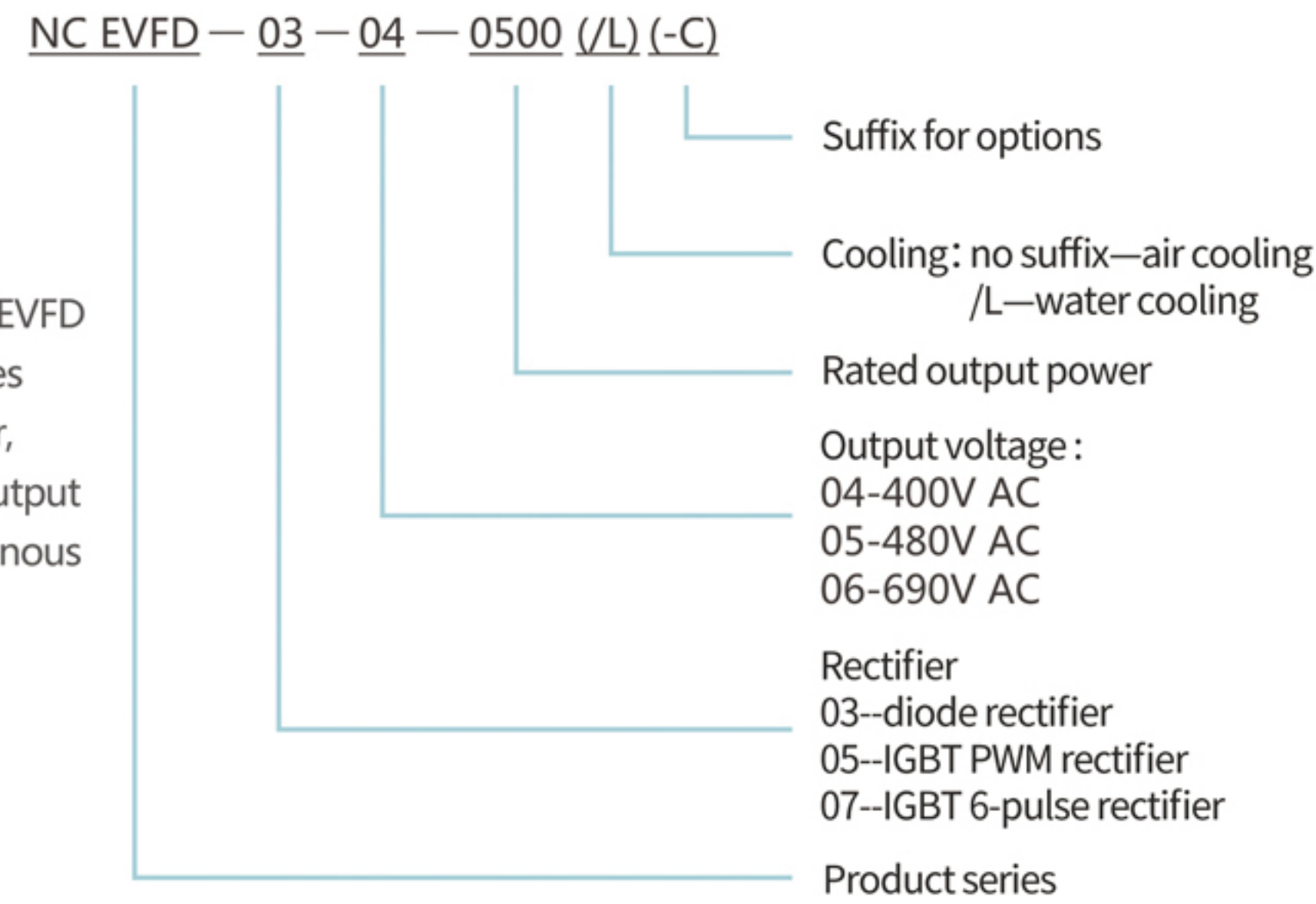

Multi-drives Model

E.g.
NC EVFD-30-06-600A states NC EVFD series Low Voltage Industrial AC Drives multi-drives, INU cabinet, air cooling, rated output voltage is 690V, and rated output current is 600A.

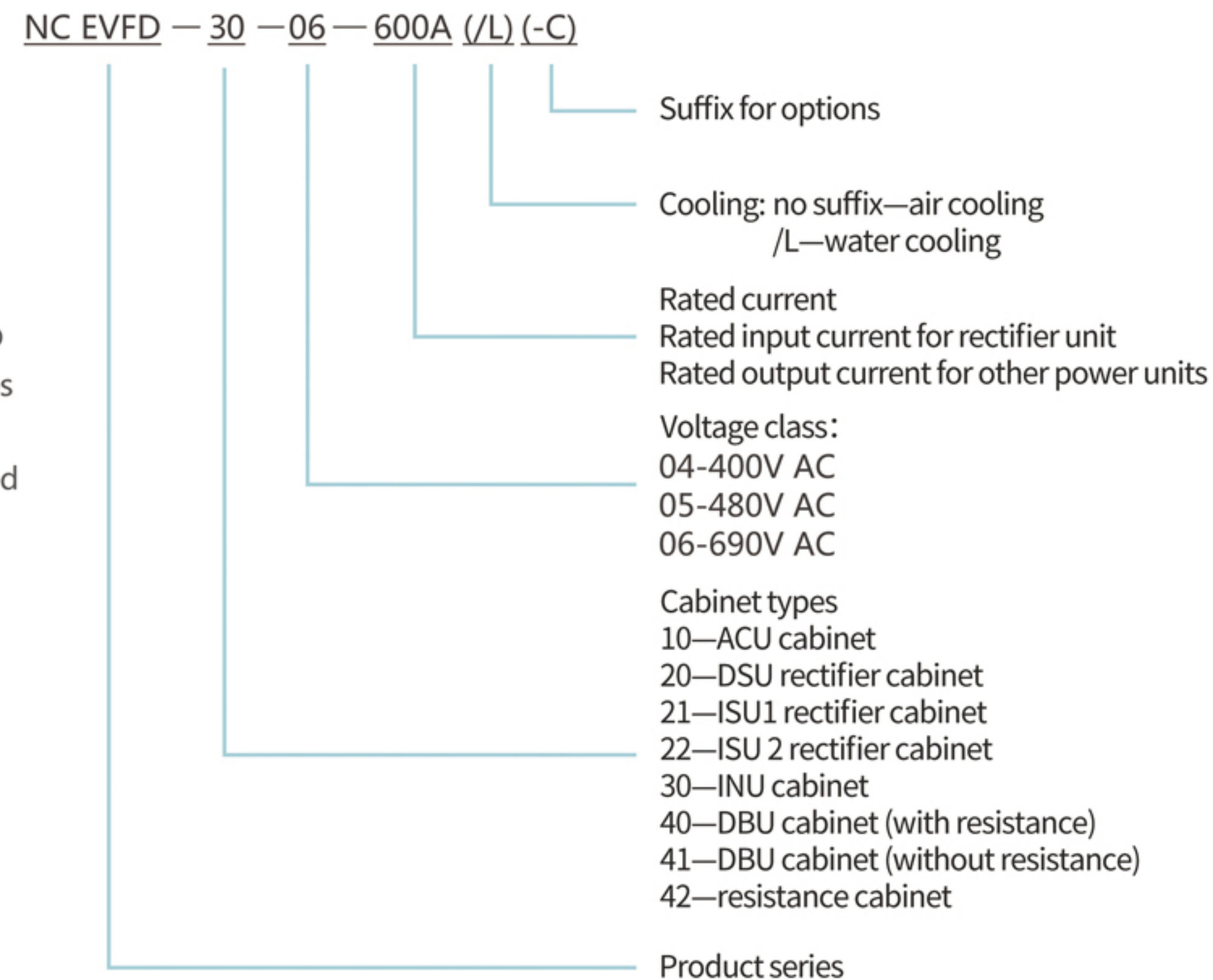

Basic information

Items		Parameters
Input	Input voltage	Three-phase, 400V: 380 ~ 415V +10%/-10%, (-15%/1 min) Three-phase, 480V: 380 ~ 480V +10%/-10%, (-15%/1 min) Three-phase, 690V: 500 ~ 690V +10%/-10%, (-15%/1 min)
	Input power factor	ISU1: 1 (fundamental), 0.99 (total) DSU, ISU2: 0.98 (fundamental), 0.93-0.95 (total)
	Efficiency (rated power)	with ISU1: 97% with DSU, ISU2: 98%
	Input frequency	48 ~ 63Hz
Output	Output voltage	400VAC/480VAC/690VAC
	Output frequency	0 ~ 300Hz (higher frequency available with special design)
	Noise	≤75dBA (1 meter)
	Color	Cabinet RAL7035 (standard)
	Enclosure	IP21 (standard)
	Control mode	Close loop vector control/speed sensorless vector control/VF control
	Motor	IM, PMSM, ESM
	Speed range	1000:1 (with speed sensor)/100:1 (sensorless)
	Torque response	<3ms
	Speed accuracy	<0.01% rated speed (with speed sensor)/<10% rated slip (sensorless)
Interface	HMI	7-inch LCD color touch screen
	Cable entry	Bottom (standard)/top
	Encoder	Encoder, resolver
	Communication	RS232/RS485/Profibus-DP/Profinet/CAN/Ethernet
	DI	7 channel, 24VDC 1A (1 channel can be configured as high-speed pulse input 10k ~ 100kHz)
	DO	3 channel, dry contact relay output (24VDC 1A or 125VAC 0.5A) 3 channel, OC output, 24 VDC (1 channel can be configured as high-speed pulse output 10k ~ 100kHz)
	AI	2 channel, 0 ~ 10V or 0 ~ 20mA, configurable
Environment	AO (option)	4 channel, 0 ~ 10V or 0 ~ 20mA, configurable
	Storage temperature	-40°C ~ +70°C
	Operation temperature	-5°C ~ +50°C (derating when exceed 40°C)
	Using place	Indoor, no explosive, corrosive, conductive dust and oil mist
	Humidity	<90% non-condensing
Altitude	<1000m (derating when exceed 1000m, 4000m maximum with customer design)	

For higher output frequency, other communication interface, extended I/O interfaces, please contact us.

Derating

• Environmental temperature

For temperature range of +40°C ~ +50 °C(+104°F ~ +122°F), rated output current will derate 1% along each degree(1°C,1.8 °F) increase. Output current can be calculated via rated current times derating factor (k).

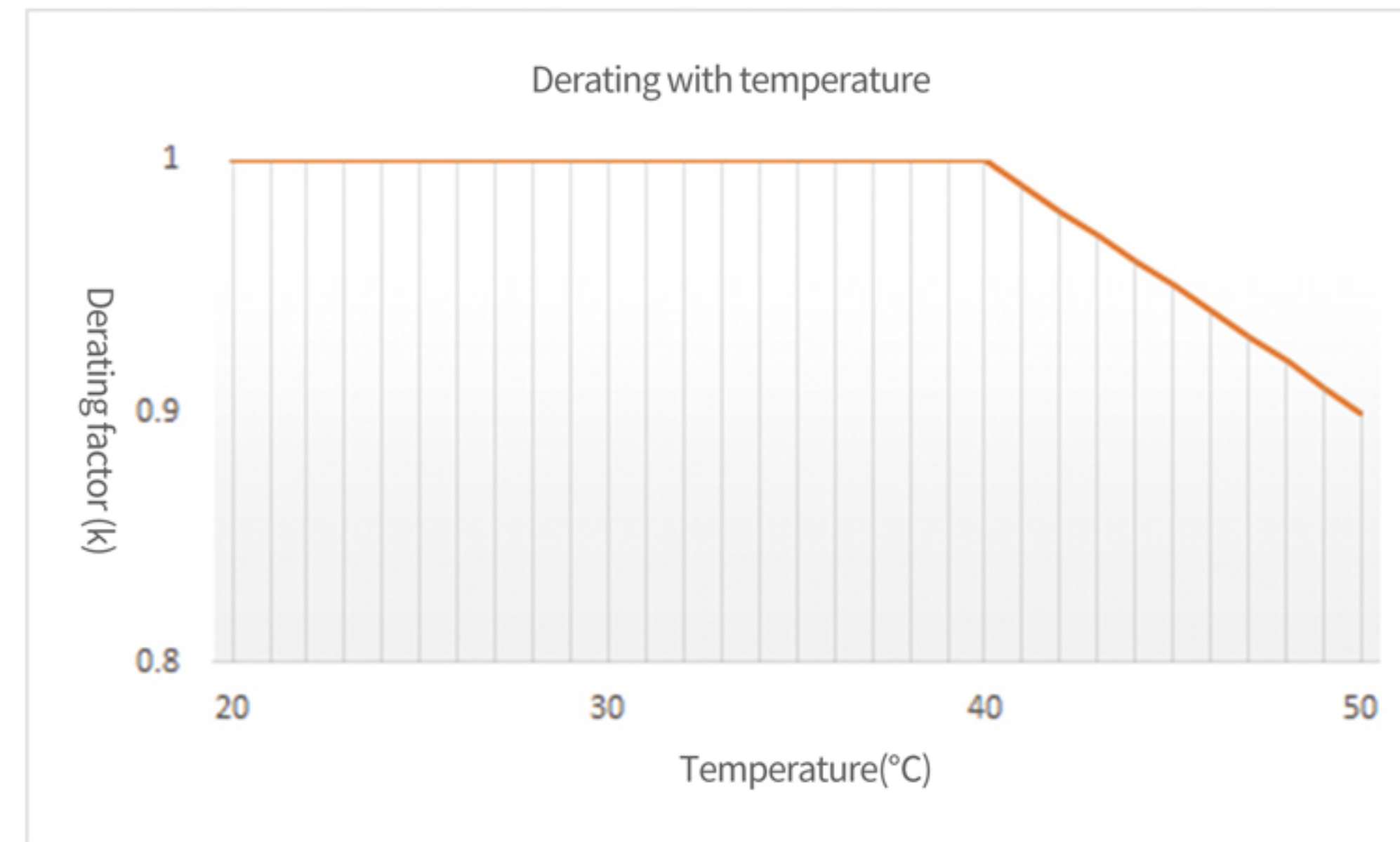

• High Altitude

For altitude range of 1000m ~ 4000m, for each 100m increase, rated output current decreases by 1%.

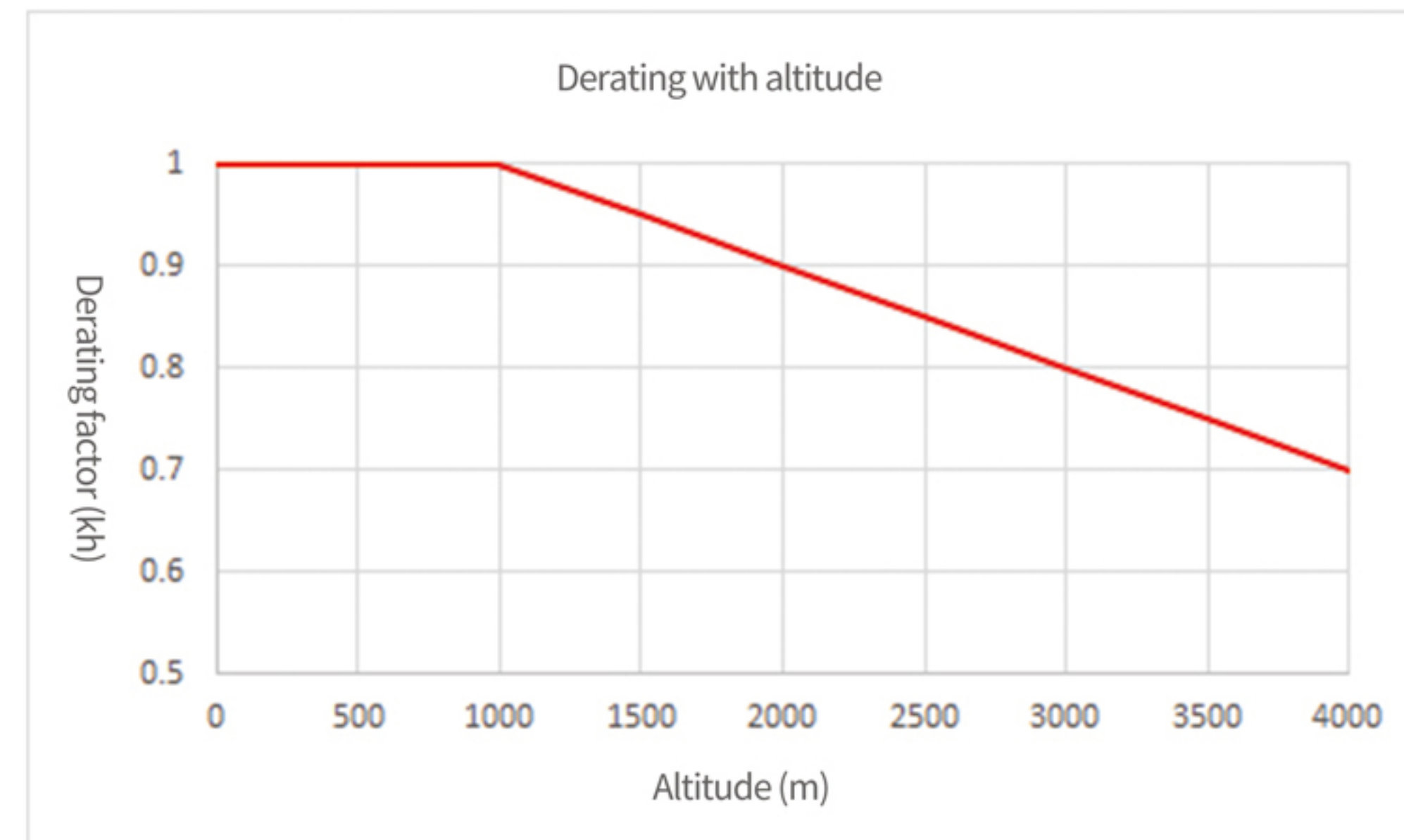

Invert Unit INU

Inverter unit convert DC to three-phase AC, to control asynchronous motor or synchronous motor. Power range of single INU is 45kW ~ 560kW, maximum 16 same type power units can be paralleled for expansion.

Rated Parameters of Single INU

INU models NCEVFD-INU	Outline (width*depth*height) mm	Rated output			Light overload		Heavy overload		Frame
		In	Imax	Pn	ILd	PLd	IHd	PHd	
		A	A	kW	A	kW	A	kW	
Un=400V AC									
-04-095A	440*550*230	95	143	45	91	45	75	37	N5i
-04-105A	189*440*903	105	147	55	101	55	79	37	N6i
-04-145A		145	203	75	139	75	109	55	N6i
-04-170A		170	238	90	163	90	128	55	N6i
-04-210A		210	294	110	202	110	158	75	N6i
-04-250A		250	350	132	240	132	188	90	N6i
-04-300A		300	420	160	288	160	225	110	N7i
-04-350A		350	490	200	336	160	263	132	N7i
-04-470A	239*587*1405	470	610	250	451	250	353	200	N8i
-04-560A		560	730	300	538	300	420	250	N8i
-04-650A		650	845	355	624	355	488	250	N8i
-04-750A		750	975	400	720	400	563	315	N8i
Un=690V AC									
-06-65A		65	91	55	62	55	49	45	N6i
-06-85A	189*440*903	85	119	75	82	75	64	55	N6i
-06-100A		100	140	90	96	90	75	75	N6i
-06-125A		125	175	110	120	110	94	90	N6i
-06-145A		145	203	132	139	132	109	110	N6i
-06-195A		195	273	160	187	160	146	132	N6i
-06-220A		220	308	200	211	200	165	160	N7i
-06-270A		270	378	250	259	250	203	200	N7i
-06-335A	239*587*1405	335	500	315	322	315	250	250	N8i
-06-430A		430	645	400	413	400	322	315	N8i
-06-530A		530	800	500	509	450	396	355	N8i
-06-600A		600	900	560	576	500	448	400	N8i

Notes

- Rated value in the 40°C (104°F) condition
- To achieve the rated motor power mentioned above, rated output current of drive must higher or equal to rated current of motor.
- For parallel INU application, please contact us.
- Parameter of 480V drive, please contact us.

Definition

Un: rated output voltage

In: rated output current (continuously and no overload)

I_{max}: maximum output current, can last 10s when startup; length of time depends on the drive's temperature in other situation.

P_n: Power of asynchronous motor with no overload

I_{Ld}: RMS output current with 110% overload, 1 min every 5mins.

P_{Ld}: motor power with light overload

I_{Hd}: RMS output current with 150% overload, 1 min every 5mins.

P_{Hd}: motor power with heavy overload

Rectifier unit

Rectifier unit convert three-phase AC to DC, and supply DC power to INU. There are three types of rectifier unit: DSU (diode rectifier), IGBT PWM rectifier ISU1 and IGBT 6-pulse rectifier ISU2.

• Diode Rectifier DSU

DSU adopt three-phase diode rectifier topology, without regeneration function, simply structure and high reliability, suitable for application with no four-quadrant requirement. The core of DSU is 6 pulses diode bridge, and the diode can convert three-phase AC to DC in DC bus and supply power to INU, both single INU and multiple INU can connect to DC bus. AC line reactor of DSU can smooth the input current and DC bus voltage.

Rated Parameters of Single DSU

DSU models NCEVFD-DSU-	Outline (width*depth*height) mm	Rated					Light overload		Heavy overload		Frame
		In _{AC}	In _{DC}	I _{max}	S _n	P _n	I _{Ld}	P _{Ld}	I _{Hd}	P _{Hd}	
		A(AC)	A(DC)	A(AC)	kVA	kW	A(AC)	kW	A(AC)	kW	
Un=400V AC											
-04-420A	239*587*1405	420	512	588	291	278	403	267	336	222	N8i
-04-580A		580	708	812	402	384	557	368	464	307	N8i
-04-640A		640	781	896	443	424	614	406	512	338	N8i
Un=690V AC											
-06-420A	239*587*1405	420	512	588	502	479	403	460	336	383	N8i
-06-580A		580	708	812	693	662	557	635	464	530	N8i
-06-640A		640	781	896	765	730	614	701	512	584	N8i

Notes

- Rated value in the 40°C (104°F) condition
- For parallel DSU application, please contact us

Definition

Un: rated input voltage

In_{AC}: rated input AC current (continually and no overload)

In_{DC}: rated output DC current (continually and no overload)

I_{max}: maximum input current, can last 10s when startup; length of time depends on the drive's temperature in other situation.

S_n: rated apparent power with no overload

P_n: rated output power with no overload

I_{Ld}: RMS input current with 110% overload, 1min every 5mins.

P_{Ld}: output power with light overload

I_{Hd}: RMS input current with 150% overload, 1min every 5mins.

P_{Hd}: output power with heavy overload

• IGBT PWM rectifier ISU1

IGBT PWM rectifier has regeneration function and support four-quadrant operation, satisfy the demand of low input current harmonic and regeneration application. The hardware structure of IGBT PWM ISU1 with four-quadrant are same as INU, convert power grid three-phase AC to DC by PWM control mode. LCL filter is the core component of ISU1 to support running. ISU1 use filter to eliminate AC current harmonic, and remove majority high frequency ripple current, the input waveform is almost sinusoidal.

Rated Parameters of Single ISU1

ISU1 models NCEVFD-ISU1-	Outline (width*depth*height) mm	Rated					Light overload		Heavy overload		Frame
		In _{AC}	In _{DC}	I _{max}	S _n	P _n	I _{Ld}	P _{Ld}	I _{Hd}	P _{Hd}	
		A(AC)	A(DC)	A(AC)	kVA	kW	A(AC)	kW	A(AC)	kW	
Un=400V AC											
-04-210A	189*440*903	210	255	273	145	144	202	138	158	108	N7i
-04-250A	239*587*1405	250	303	325	173	171	240	165	188	129	N8i
-04-500A		500	606	650	346	343	480	329	375	257	N8i
-04-675A		675	818	878	468	463	648	444	506	347	N8i
Un=690V AC											
-06-300A	239*587*1405	300	364	390	359	355	288	341	225	266	N8i
-06-400A		400	485	520	478	473	384	454	300	355	N8i
-06-450A		450	545	585	538	532	432	511	338	399	N8i

Notes

- Rated value in the 40°C (104°F) condition
- For parallel ISU1 application, please contact us
- For information of LCL filter, please contact us

Definition

Un: rated input voltage

In_{AC}: rated input AC current (continually and no overload)

In_{DC}: rated output DC current (continually and no overload)

I_{max}: maximum input current, can last 10s when startup; length of time depends on the drive's temperature in other situation.

S_n: rated apparent power with no overload

P_n: rated output power with no overload

I_{Ld}: RMS input current with 110% overload, 1min every 5mins.

P_{Ld}: output power with light overload

I_{Hd}: RMS input current with 150% overload, 1min every 5mins.

P_{Hd}: output power with heavy overload

• **IGBT 6-pulse rectifier ISU2**

IGBT 6-pulse rectifier has regeneration function and support four-quadrant operation, satisfy the demand of low cost and re-generation application. The hardware structure of IGBT PWM ISU2 with four-quadrant are fundamental same as INU and ISU1, convert three-phase AC to DC by 6-pulse control mode. ISU2 are cost-effective than ISU1, because IGBT only switch once during half cycle of power grid voltage, resulting low switching loss and higher rated current. Also, high reliability under network malfunction in regeneration mode since IGBT can turn off anytime. While input current harmonic are similar to DSU, need input reactor L in the input terminal.

Rated Parameters of Single ISU2

ISU2 models NCEVFD-ISU2-	Outline (width*depth*height) mm	Rated					Light overload		Heavy overload		Frame
		In _{AC}	In _{DC}	Imax	Sn	Pn	ILd	PLd	IHd	PHd	
		A(AC)	D(DC)	A(AC)	kVA	kW	A(AC)	kW	A(AC)	kW	
Un=400V AC											
-04-500A	239*587*1405	500	610	650	346	343	480	329	375	257	N8i
-04-750A		750	915	975	520	514	720	494	563	386	N8i
Un=690V AC											
-06-400A	239*587*1405	400	488	520	478	473	384	454	300	355	N8i
-06-500A		500	610	650	597	590	480	567	375	443	N8i
-06-600A		600	732	780	717	710	576	681	450	532	N8i

Notes

- Rated value in the 40°C (104°F) condition
- For parallel ISU2 application, please contact us
- For information of line reactor, please contact us

Definition

Un: rated input voltage

In_{AC}: rated input AC current (continually and no overload)

In_{DC}: rated output DC current (continually and no overload)

Imax: maximum input current, can last 10s when startup; length of time depends on the drive's temperature in other situation.

Sn: rated apparent power with no overload

Pn: rated output power with no overload

ILd: RMS input current with 110% overload, 1min every 5mins.

PLd: output power with light overload

IHd: RMS input current with 150% overload, 1min every 5mins.

PHd: output power with heavy overload

Braking Unit DBU

Braking unit consume energy through braking resistance to prevent the pumping up of DC bus voltage caused by INU regeneration, it is used in demand of motor braking operation without four-quadrant rectifier unit. Braking unit consist of DBU and braking resistor (R). When DC bus voltage exceed the set value, DBU will connect braking resistance to DC bus via IGBT switch on, and power dissipation on braking resistor will decrease DC bus voltage continually until IGBT switch off. In fact, DBU is similar to three-phase INU, input terminal connects to DC bus, and output terminal connects individual braking resistor.

Rated Parameters of Single DBU

DBU models NCEVFD-DBU-	Outline (width*depth*height) mm	Resistor	No overload			Periodic overload (1min every 5mins)		Frame
		Rmin	Irms at Rmin	Imax	Pn	Irms at Rmin	Pbr at Rmin	
			Ω	A(DC)	A(DC)	kW	A(DC)	
Un=400V AC								
-04-260A	239*587*1405	2.1	260	312	421	294	539	N8i
-04-390A		1.4	390	468	632	441	809	N8i
Un=690V AC								
-06-260A	239*587*1405	3.6	260	312	727	294	930	N8i
-06-470A		2.0	470	564	1313	531	1681	N8i

Notes

- For parallel DBU application, please contact us
- For information of braking resistor R, single phase DBU, please contact us

Definition

Un: input voltage for VFD

Rmin: minimum resistor value of each phase

No overload

Irms: output DC current of each phase (continually and no overload)

Imax: maximum current of each phase of DBU

Pn: maximum continually braking power

Periodic overload

Irms: each phase DC current in 1min at braking power of Pbr

Pbr: short-time braking power in 1min every 5mins

Applications



Metallurgical cold rolling



Metallurgical hot rolling



Metallurgical rod and wire



Oil drilling machine



Top drive drilling rig



Electrical submersible pump



Mine hoist



Marine propulsion



Harbor belt conveyor



Papermaking



AC power source



Marine



Port crane



Test bed



Rubber and plastics



Pump and fan



Cement



Extruder/compressor/centrifuge



Mine electrical shovel



Ocean platform

Application Case

Nancal provides total solution and project implementation of low voltage electric drive and automatic control system for reversible cold rolling mill in Ningbo, China.

The project includes 6 machines, 2 sets main rolling machine, 2 sets main winding/unwinding machine and 2 sets small winding/unwinding machine, main winding motor and small winding motor adopts coaxial drive. And all motors are driven by NC EVFD series Low Voltage Industrial AC Drives. The input voltage of VFD is 690V, use IGBT 6-pulse rectifier ISU2 with regeneration function, common DC bus. High performance vector control provide excellent performance of speed and tension control, save costs and space.

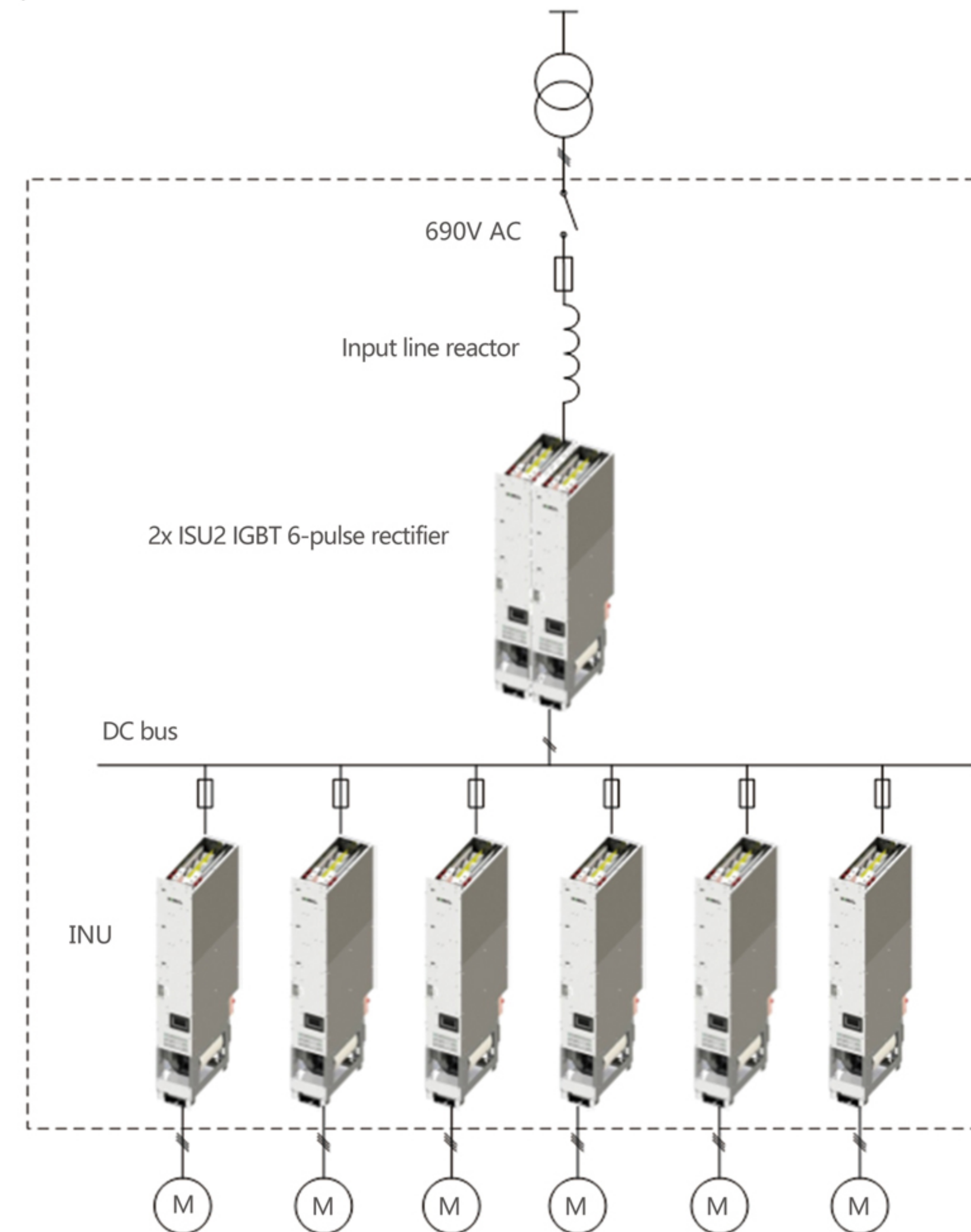

Glories

- SIL2 certificate
- CE certificate
- Patents for invention
- ISO 9001/ISO 14001/OHSAS 18001
- Software enterprise certificate
- National high and new technology enterprise



• Low Voltage Industrial AC Drives

• Power Unit



• HMI



• Rolling mill in operation



• Wide thin-strip rolling



• Recoiling machine in operation

